

A FORCE TO TRUST.

MJP
MARINE JET POWER

MJP IS THE WORLD LEADER IN WATERJET PROPULSION, BUILT AS
A FORCE TO TRUST.
SO YOUR ONLY LIMITATION IS HOW HARD YOU HIT THE THROTTLE.

PARTNERSHIP

Only after listening, asking, reflecting, and reviewing do we provide initial recommendations for your specific vessel needs. Providing quick answers and the right advice is at the heart of our service. Let's say your one-of-a-kind build requires speed and low fuel consumption on a tight budget or your large vessel will run 24/7 and is tight on space. Our team gets excited to tackle these challenges. They work closely with our highly skilled engineers to present the best waterjet for your unique build. And they'll be your partner throughout the build, installation, launch, and servicing to make sure your vessel performs as designed.

PERFORMANCE

Every single detail of an MJP waterjet is measured against our goal: enhance boat performance. This is reflected in everything we do. Our manufacturing team builds each jet with the best tools available in our state of the art facilities. Our highly skilled engineers work and rework every part trying to add just a little more efficiency. Our sales and service teams, located around the globe, are quick to deliver on commitments and are always standing by so you are never left waiting. At every turn, we are focused on performance. Not just speed, power, and fuel economy, but in every deliverable, from the initial discussion to our 5 year warranty—everything must aid in enhancing the performance of your vessel. At MJP, we are a Force to Trust.

MARKETS SERVED

GOVERNMENT
PASSENGER VESSELS
WORK BOATS
YACHTS
COMMERCIAL FISHING

HIGHLY ENGINEERED WATERJETS

At MJP, we aim to make propulsion that enables captains of all disciplines to achieve their daily tasks with efficiency and speed—without fear of a breakdown or high operating costs. To get the absolute most out of each voyage, our products are tailored precisely for the captain and the job at hand, in a highly engineered and durable package. This has led us to categorically unique mixed-flow, and axial flow waterjets that prove time and time again to be the toughest, fastest, most efficient, and most reliable on the market.

X-SERIES MIXED-FLOW WATERJET

PROVEN PUMP DESIGN

MJP's proprietary pump design features a stainless steel impeller and proven mixed-flow technology for maximum efficiency and high speeds.

MIXED FLOW

Creates thrust using a combined radial and axial flow to achieve high propulsive efficiency.

OPTIMIZED INTAKE GEOMETRY

Optimal performance over the complete speed range, without impacting top-speed capabilities.

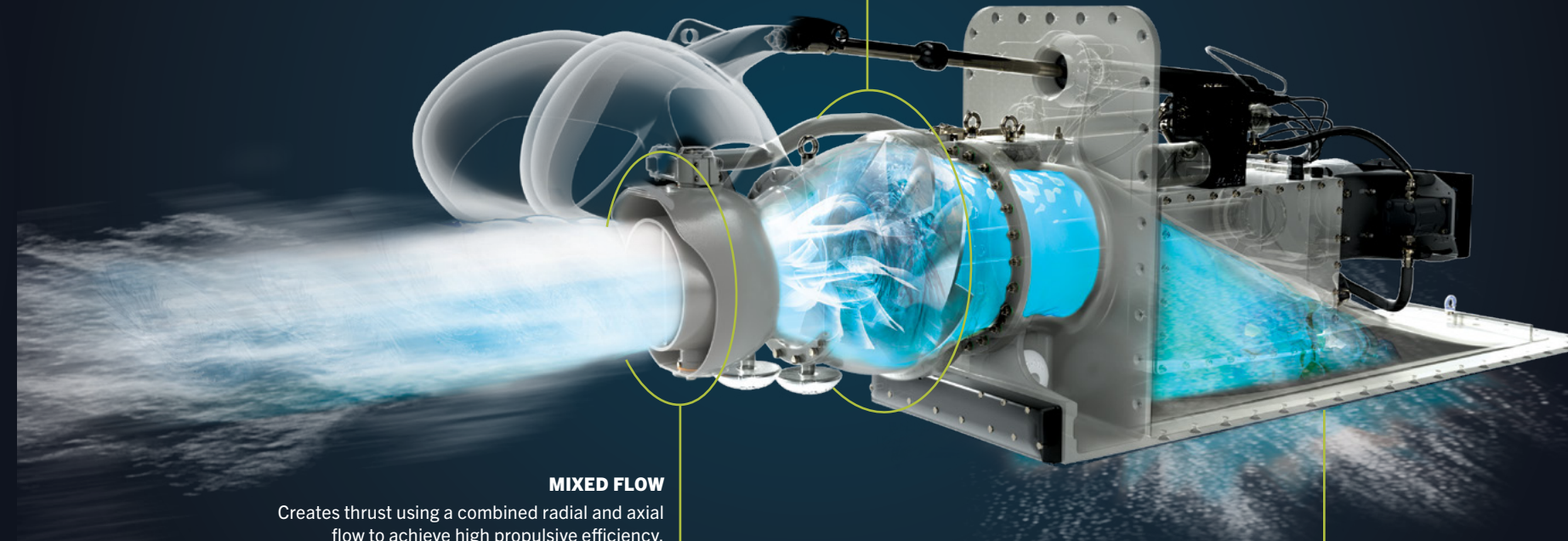

35 YEARS AND COUNTING

UNSTOPPABLE

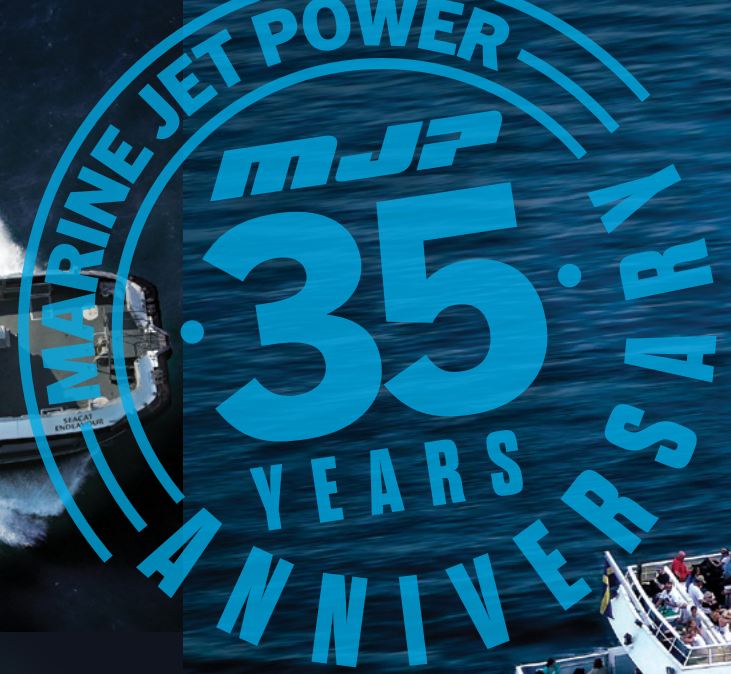
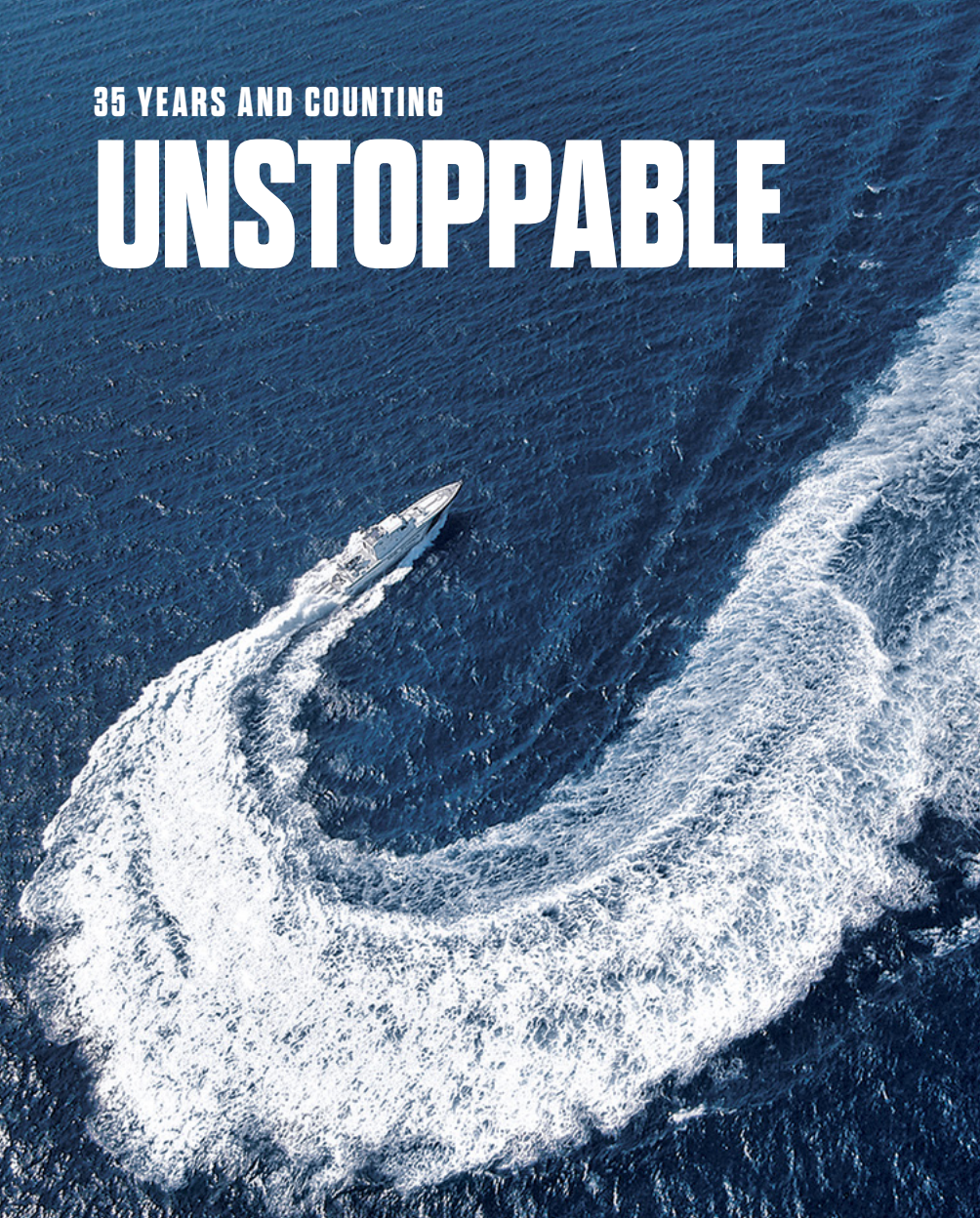

CINDERELLA II

Marine Jet Power delivered its first ever set of waterjets in 1987 to the M/S Cinderella II. Today, you can still find the M/S Cinderella II operating in the Stockholm Archipelago. Over 35 years later, with original MJP waterjets still in operation, the 350-passenger ferry operates a daily schedule from Central Stockholm to Sandhamn Island in Sweden.

- LENGTH:** 41-METER
- SPEED:** 24 KNOTS
- ENGINE POWER:** SCANIA
- YEAR:** 1987
- WATERJETS:** (2) MJP 550 CSU

COMPACT STEERING UNIT

CLASSIC MIXED-FLOW HIGH-EFFICIENCY WATERJET

APPLICATIONS

Large Commercial Crafts
Governmental Applications
Passenger Ferries
Yachts



DESIGNED FOR SMALL SPACES

The CSU bucket design is optimized for installations where split duct reversing buckets will not fit. The classic bucket design allows for closer center to center installations.

MIXED-FLOW HIGH-EFFICIENCY PUMP DESIGN

Excellent maneuverability
Superb acceleration
High top speed

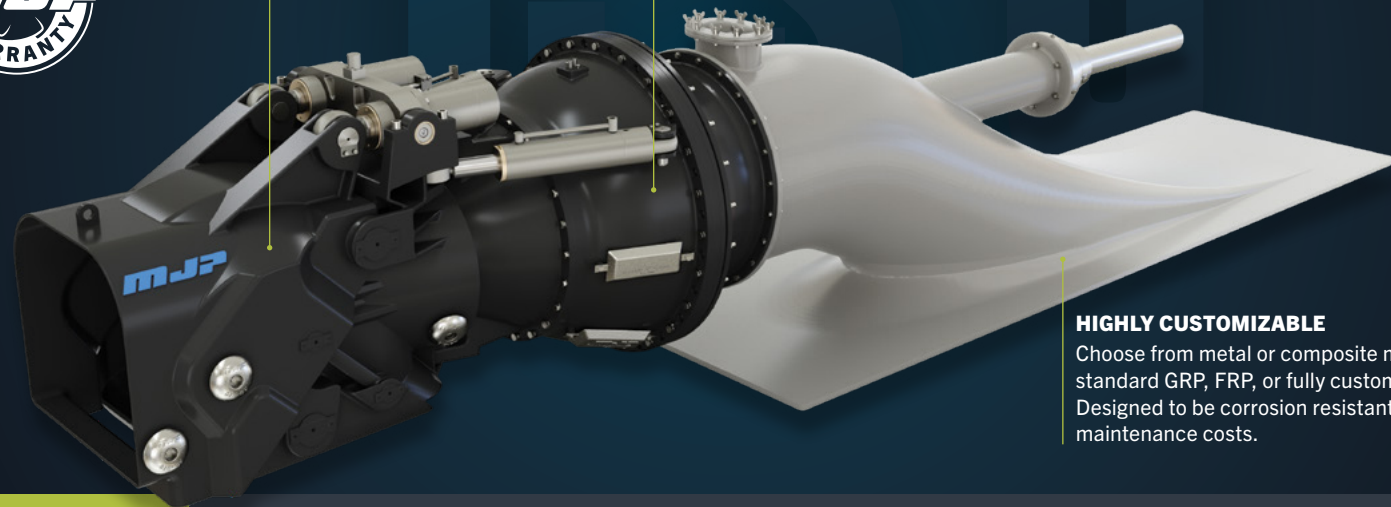

HIGHLY CUSTOMIZABLE

Choose from metal or composite materials in a standard GRP, FRP, or fully customized shape. Designed to be corrosion resistant—reducing maintenance costs.

CSU

MAX KW MAX BHP

1,500 kW–21,000 kW
2,011 BHP–28,161 BHP

MATERIALS

| | |
|----------|------------------------|
| Body | Duplex Stainless Steel |
| Impeller | Duplex Stainless Steel |
| Intake | Metal or Composite |

FOR VESSELS

26m - 200m



YOUR SCHEDULE IS TOO TIGHT FOR A BREAKDOWN

When you're running all day, every day across a harrowing channel carrying precious cargo, the Compact Steering Unit (CSU) is your engine that could. Offering low fuel consumption, long range, and high speeds, you'll be on time, every time. The CSU's precision engineered duplex stainless-steel structure is 2x stronger than standard stainless and is more corrosion resistant keeping you on the water longer. The CSU's steering unit provides precise direction control while the indestructible duplex stainless steel construction provides superior operational functionality and efficiency. Built to keep you and your passengers where they need to be quickly and comfortably. All aboard.

Red Jet 4

Red Jet 4 is a 39m Catamaran designed and built for the Red Funnel Group UK to operate a busy daily commuter service from Southampton to Cowes on the Solent. Red Jet 4 achieved the 35 knot contract speed fully loaded at only 80% MCR. The vessel exceeded contract speed by 3.1 knots and reached 38.1 knots at full deadweight and 41.0 knots when lightly loaded.



DOUBLE REVERSING BUCKET

MIXED FLOW HIGH-EFFICIENCY WATERJET WITH INBOARD HYDRAULICS

APPLICATIONS

Large Commercial Crafts
Governmental Applications
Passenger Ferries
Yachts



MIXED-FLOW HIGH-EFFICIENCY PUMP DESIGN

Excellent maneuverability
Superb acceleration
High top speed

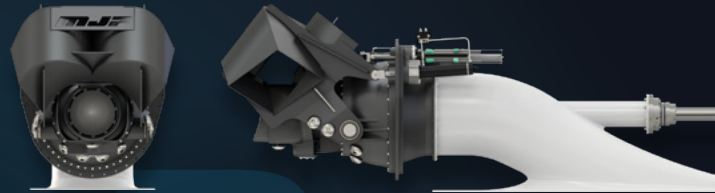

INBOARD HYDRAULICS

Hydraulics are mounted inside of the hull
Ideal for small installation spaces
Highly customizable
Built-in thrust bearing floating drive shaft

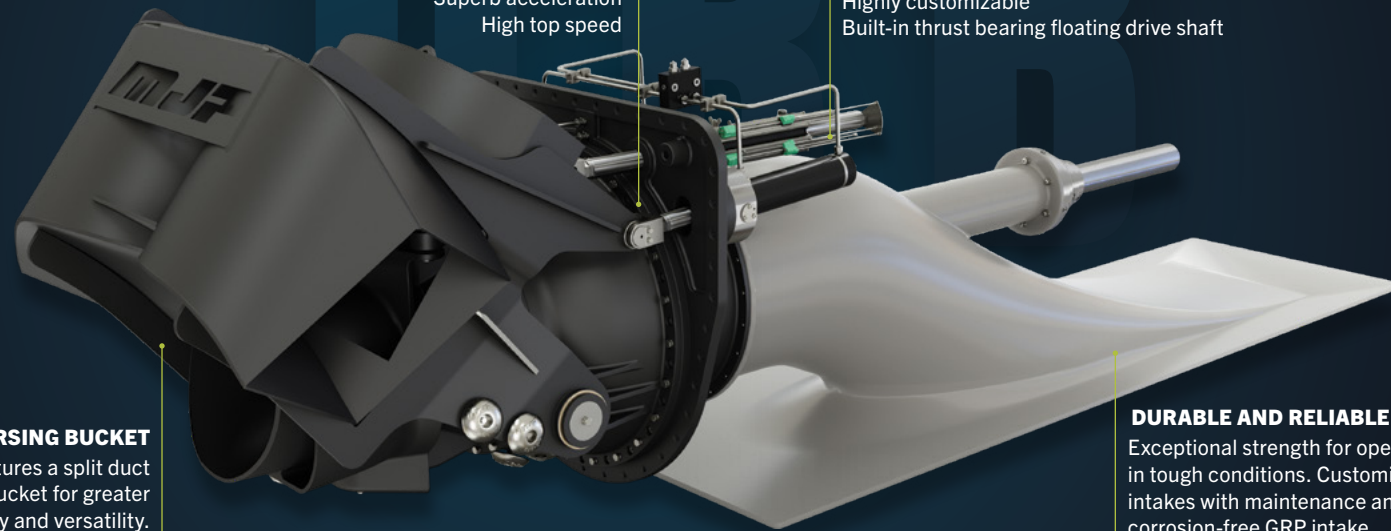

DOUBLE REVERSING BUCKET

The DRB features a split duct reversing bucket for greater maneuverability and versatility.

DURABLE AND RELIABLE

Exceptional strength for operation in tough conditions. Customized intakes with maintenance and corrosion-free GRP intake.

DRB

MAX KW MAX BHP

1,000 kW–9,000 kW
1,341 BHP–12,069 BHP

MATERIALS

Body Duplex Stainless Steel
Impeller Duplex Stainless Steel
Intake Metal or Composite

FOR VESSELS

26m - 200m



GET IN GET OUT

Operating in debris filled water and hitting sand and stones, a typical Tuesday morning. We think that's the point. Our duplex stainless steel pumps eat rocks and sand for breakfast. So you can run aground and shrug off the rock you just turned into a paper weight to keep your focus on dropping off your payload and getting back to sea.

Our Double Reversing Bucket line (DRB) offers an inboard hydraulic design and high performance pump technology to provide you with additional maneuverability and increased reversing speeds to get you in and out before they even realized you were there. Superior performance. Unmatched service life. All in a day's work.

IC20M BY DOCKSTAVARVET

Based on Docksta's well-proven experience in fast police and patrol craft, the IC20M is a 20m vessel featuring dual MJP 450 DRB waterjets. Capable of a top speed of 45 knots, this vessel is powered by 1600hp MTU engines.



X-SERIES

HIGH-SPEED, FUEL EFFICIENT, MIXED-FLOW WATERJET

APPLICATIONS

High-Speed Craft
Patrol Vessels
Governmental Applications
Rescue Craft



HIGH SPEED / LOW COST

Extremely low maintenance costs paired with incredible performance makes the X-Series an out-of-the-box powerhouse

MIXED FLOW DUPLEX STAINLESS STEEL PUMP

The X-Series proven pump design has been designed and engineered for maximum efficiency at high speeds.

READY-TO-GO INSTALL

A complete jet assembly with integrated hydraulics housed in an aluminum frame for welding or bolting into hull structure. Designed for small spaces.

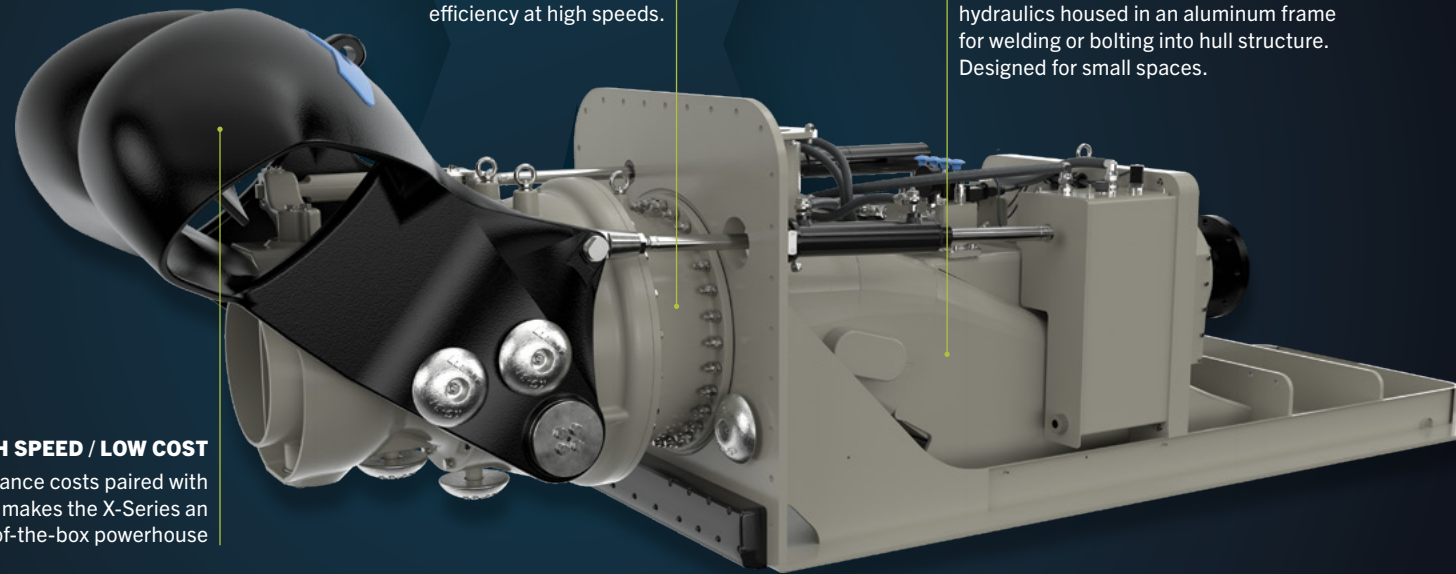
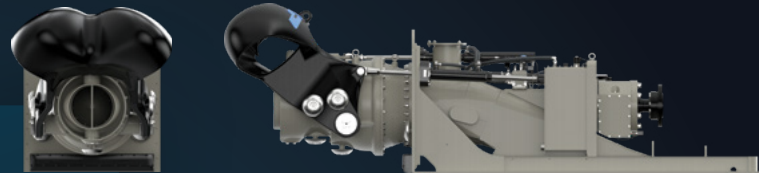

X

MAX KW MAX BHP

611-2,070 kW
819 - 2,776 bhp

MATERIALS

Body Aluminum
Pump Unit Duplex Stainless Steel
Intake Aluminum

FOR VESSELS

12-40m



BUILT FOR X-SPEED

This completely re-imagined waterjet is ushering in a new era of water propulsion performance. You asked for speed and we delivered the X-Series. With an optimized mixed flow pump capable of speeds in excess of 50 knots, buckle up. Built from duplex stainless steel, this unit is stronger, lighter, more efficient, and more corrosion resistant to keep you on the water and moving faster when every second counts. With the all new redesigned cast aluminum reversing bucket and optimized intake, you'll be stopping on a dime and performing lightning fast maneuvers like a cheetah on the hunt. Seatbelts not included.



Firestorm - 55' Firefighting Vessel

Built by Metal Shark, this state of the art firefighting vessel houses MJP 350X waterjets powered by MAN 1200hp V8 engines capable of top speeds in excess of 50 knots. Operated by Miami-Dade Fire Department.

ULTRAJET

HIGH THRUST AXIAL FLOW ALUMINUM WATERJET

APPLICATIONS

Commercial Fishing Vessels
Military Craft
Commercial Work Boats
Crew Transfer Vessels

TESTED AND PROVEN PUMP DESIGN

With more than 15,000 units in service today, the UltraJet pump is proven to perform in some of the harshest conditions in the world.

ALL-IN-ONE WATERJET

A complete jet assembly with a variety of on-jet and remote-mounted hydraulic control systems allows for quick and easy maintenance and installation.

HIGH THRUST INTAKE

Optimized for high-thrust and maximum bollard pull.

FOR VESSELS

8m - 17m

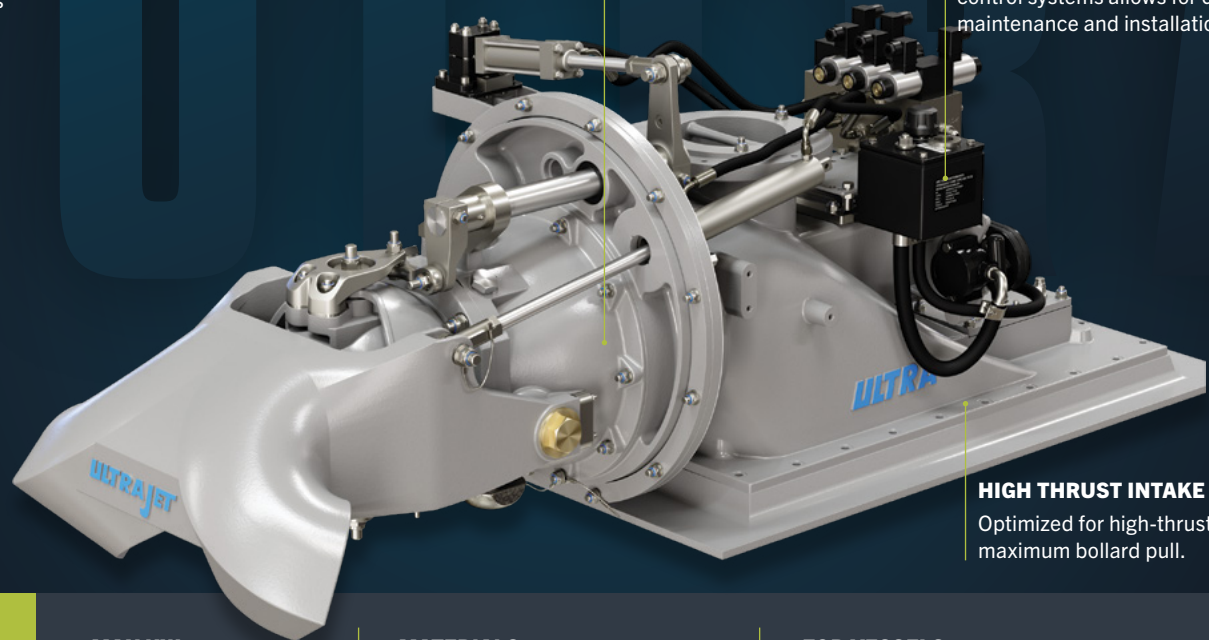

BIG PAYLOAD BIG POWER

A short season means there's no room for failure. Fear not. Go ahead, push your boat to the limit. Our UltraJet is built with you in mind. Where reliability is paramount, efficiency at high thrust is expected, and performance with an oversized load is sublime. So push, pull, transfer or haul that payload with confidence and keep your focus on completing your mission. We make your business our business. Trust UltraJet to get it done.



Smoky Point - Cordova, AK

The Smoky Point was specifically designed and engineered for the rigors of the Bristol Bay, Alaska sockeye (red) salmon fishing season. This 32' vessel is equipped with Cummins 8.3L 600hp QSC engines and MJP UltraJet 340HT waterjets with a 5 blade impeller capable of 39 knots.

ULTRA

MAX KW MAX BHP

261 kW—448 kW
350 BHP—600 BHP

MATERIALS

Body Aluminum
Impeller Aluminum
Intake Aluminum

ELECTRIC & HYBRID SOLUTIONS

Marine Jet Power is charging into the future with our all new line-up of electric and hybrid waterjet solutions. Our goal is to reduce total energy consumption and CO2 emissions while offering improved performance, intelligent technology, and the trusted quality that you've come to expect from MJP.

We have worked closely with our marine industry partners to engineer two electric/hybrid options that produce serious power and reliability. We recognize that one solution doesn't fit all and each situation poses its own challenges which is why we are offering multiple configurations and a team of dedicated experts to help create the electric/hybrid solution that works best for you.

PTI - POWER TAKE-IN ON THE GEARBOX

This established and reliable solution is the preferred solution for many shipyards and designers. It works through a power take-in (PTI) located on the gearbox driven by an electric motor.

ELECTRIFIED POWER SYSTEM BETWEEN THE GEARBOX AND ENGINE

The modular and scalable hybrid electric system is located in-between the gearbox and diesel engine, improving powertrain performance with exceptional torque making it a great solution for hybrid waterjet installations. This hybrid option offers lower fuel consumption, lower operational costs and can significantly reduce CO2 emissions. This solution is commercially available for diesel engines up to 864kW and compatible with the MJP X-Series waterjets.

SCANIA E-MACHINE

Hybrid Electric Power systems by Scania offer up to 92% potential CO2 emissions reduction as well as lowered fuel consumption and improved powertrain performance.

JETMASTER 3 CONTROL SYSTEM

NEXT-GEN LINE OF PRECISION CONTROLS

At MJP we do everything we can to deliver ultimate performance to the captain. That's why we have engineered our line-up of Jetmaster 3 Controls to give you total command at full throttle or hairline precision while maneuvering in the harbor.

Extreme engineering and fanatical testing make our controls the most capable on the market. Our endless combination of features and controls, ease of use, and intuitive movements will give you complete mastery of your vessel even in the harshest conditions.

OPTIONS

- Unlimited station configurations
- Analog helm command panel
- Drive up to 4 waterjets
- 2 redundant computer systems
- Available backup system in case of emergency shut down
- Optional control heads available

SOFTWARE OPTIONS FOR JETMASTER 3 CONTROLS



DYNAMIC POSITIONING

MJP's DP0 mode provides GPS positioning control to stay on spot, hold heading and virtual anchoring.



3RD PARTY DYNAMIC POSITIONING

MJP's dynamic positioning software communicates with most 3rd party dynamic positioning systems.



UNMANNED / AUTONOMOUS MODE

Remotely access the Jetmaster 3 system through raw, calibrated, formatted & custom data types.



3RD PARTY BRIDGE INTEGRATION

A safe, secure, and firewalled method for 3rd party bridge systems to access and display waterjet data.



INTERCEPTOR INTEGRATION

Control your vessels interceptors, rudders, and/or fins. Both coordinated turn and steering assist modes.



VECTOR CONTROL SYSTEM

Gain precision control of harbor maneuvers and low speed positioning at sea. Idle RPM speed can easily be adjusted to increase responsiveness.



TROLLING MODE

Troll, stop, accelerate, spin, and reverse the vessel with ease. Avoid water turbulence or entanglements of lines.



FIRE-FIGHTING MODE

Share engines between fire-fighting and prevent accidental damage to gearboxes and inadvertent acceleration of the vessel.



Bridge from the AB 100 Superyacht Spectre



COMBINATOR THROTTLE

Single or twin lever for forward and reverse thrust with optional engine RMP and clutch integration.



JOYSTICK

Full and true vector control in harbor or at slow speed, close quarter maneuvering. Clutch control and autopilot available.



STEERING WHEEL

Port and starboard steering with optional tiller steer and armrest mounted intuitive autopilot integration.



TOUCH SCREEN DISPLAY

7 or 15-inch touch screen display for waterjet control and diagnostics.

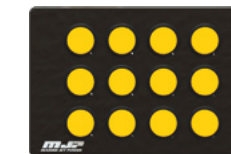

CONTROL PANEL

Analog control panel with fully customizable button functions.

WORLD CLASS SUPPORT

You've taken delivery of your vessel and broken the champagne bottle. Feel the incredible force as you lean on the throttle and quietly glide through the harbor. Your relationship with MJP has just begun. When you make the decision to trust MJP to propel your livelihood, the team is available to you every day for the lifetime of ownership. Whether you call with a maintenance question, need hands-on personal training, or find you would like to make adjustments to your control system, we value the chance to connect with you and hear all about your travels. At MJP, you have become a member of our extended family and we are here for you every step of your voyage.



We take pride in our dedication to keep your vessel operating 24/7–365. Our global service organization is on standby to assist you with parts, training, upgrades, and on-site service whenever or wherever your operation leads you. And our market leading 5-year warranty is just another way to prove that dedication to you.

WHAT WE OFFER

- Installation Support
- Technical Support
- On-site Service
- Genuine Spare Parts
- Service Level Agreements
- Onboard Training Certification
- Swing Units
- Factory Impeller Refurbishment
- Upgrades

CONTACT US

service@marinejetpower.com
spareparts@marinejetpower.com

A FORCE TO TRUST

Marine Jet Power is the result of 35+ years of dedication to building the best waterjets in the industry. With MJP employees and authorized sales and services agents worldwide, MJP has helped the maritime industry create faster, safer, more efficient, and more maneuverable vessels throughout the world. We are a Force to Trust.





-  /marine-jet-power
-  /MarineJetPower
-  Marine Jet Power
-  /mjpowerjets

MARINE JET POWER

Hansellsgatan 6
754 50 Uppsala
SWEDEN
+46 (0) 10 165 10 00

SOUTH KOREA

Gamcheonhang-ro 165-4, Saha-gu
49454 Busan
KOREA
+82 (51) 746 6428

AMERICAS

6740 Commerce Ct. Drive
Blacklick, OH 43004
USA
+1 614-759-9000

Sales@marinejetpower.com